



REM.D.RA

CALIBRATION PROCEDURE	CAP. IX • 8
OVERALL DIMENSIONS	CAP. IX • 10
MOUNTING BASES	CAP. IX • 10

ORDERING CODE

- REM** Miniaturized electronic regulator in Undecal type container
- D** Double solenoid
- RA** Asymmetrical ramp
- *** Maximum output current I_{MAX} (JU variant)
X = 0.88 A (0.80 A)
Y = 1.76 A (1.20 A)
Z = 2.8 A
- *** Input reference (V) see note (*) below
2 = -2 ÷ +2 V
5 = -5 ÷ +5 V
0 = -10 ÷ +10 V
A = -20mA ÷ +20mA
0 ÷ +20mA
- *** Frequency Dither
1 = 100 Hz (standard, JU var.)
2 = 330 Hz
- G** Minimum initial current can only be adjusted in steps
- **** **00** = No variant
- 4** Serial No.

(*) If the input reference is a current signal (mA) the regulator has to be pre-setted in the factory.

• **CE** registered mark for industrial environment with reference to the electromagnetic compatibility. European norms:
 - EN61000-6-2 general safety norm - industrial environment
 - EN61000-6-4 emission general norm - residential environment
 • Product in accordance with **RoHS** 2011/65/UE European Directive.

REM.D.RA... TYPE ELECTRONIC REGULATORS

DOUBLE SOLENOID PROPORTIONAL CONTROL VALVES

The electronic control card type REM.D.RA has been designed to drive the double solenoid proportional valves series "XD.*.C..." and "XDP.3.C" without integral position transducer. The control card is enclosed in an "UNDECAL" type housing, a typical relay mounting standard. The output stage operates on the pulse width modulation principle (P.W.M.) and is provided with current feedback in order to obtain a solenoid output current proportional to the reference input signal.

Output short circuit and supply polarity inversion protection is provided. Gain, minimum current and rise and fall ramp time adjustments are possible through the corresponding front panel trimming potentiometers, while the output current to the solenoid can be measured via the Valve Current test points, and the ramps can be excluded.

The product incorporates a serial interface for adjustment of parameters.

Pay attention please: electronic regulators must be used in dampness and water protected places.

Manuals and software

The user and installation manual, the manual for variants DJ/JU and the software DG are available on "products" section of www.brevinifluidpower.com website (put REMD on internal search engine).

Supply
Overload
Ramp off
Output
I. min.
Gain
Ramp up
Ramp down
GND
1V/A

ADJUSTMENT PANNEL

10Vdc ÷ 30Vdc (green led)
 Protection against over (red led)
 Ramp off (red led)
 Output (current at solenoid A/B, yellow led)
 Minimum current adjustment A/B
 A/B gain adjustment
 A/B ramp up adjustment time
 A/B ramp down adjustment time
 Ground
 Current test point at solenoid

If any field is missing from the ordering code the standard setting is as follows:

- Input ref. = -5 ÷ +5V
- Dither = 100Hz
- I_{max} = 0.8A

ELECTRICAL CIRCUIT AND CONNECTIONS

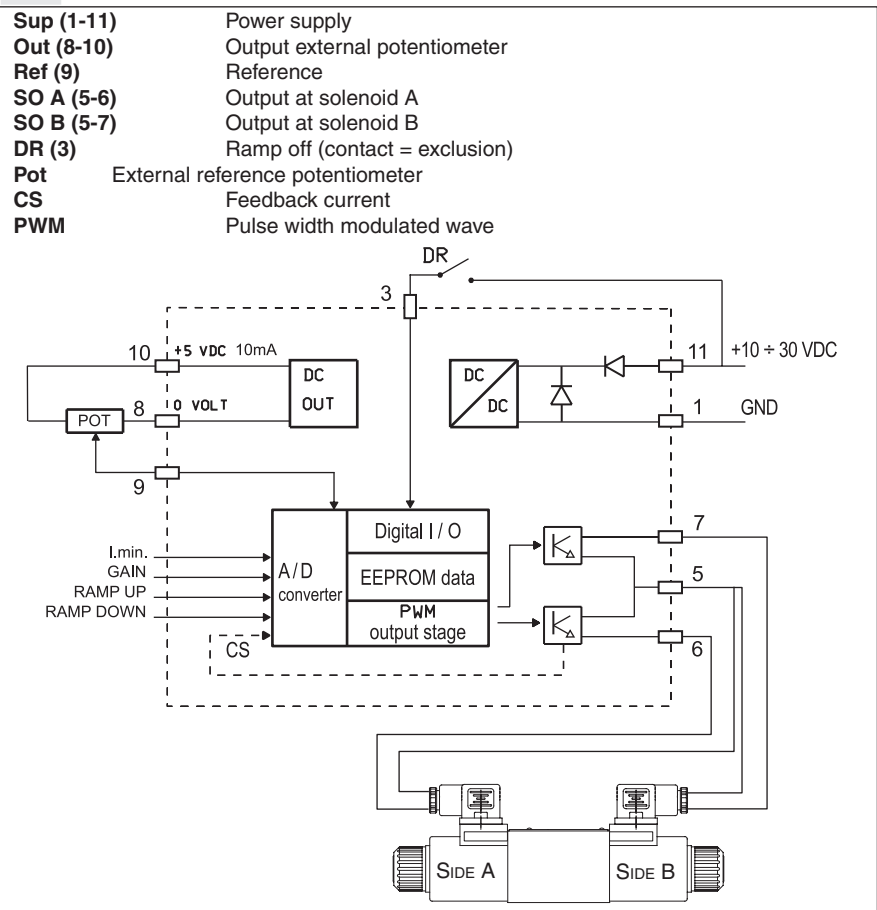

ELECTRONIC REGULATORS DOUBLE SOLENOID PROPORTIONAL CONTROL VALVES

Power supply	10 ÷ 30 VDC
Maximum supply voltage	36 V
Power absorption	40 W
Current output setting by dip switches	I _{max} = 2.8A I _{max} = 1.76A I _{max} = 0.88A
External potentiometer supply output short circuit protected	+5V I _{max} .10mA
Reference input signal setting by dip switches	-2V ÷ +2V -5V ÷ +5V -10V ÷ +10V -20A ÷ +20mA (*)
Signal input reference (pin n° 9) setting by dip switches	0V ÷ +5V 0 ÷ +20mA (*)
Polarization current adjustment	I _{min} = 0 ÷ 50% I _{max}
Current gain adjustment	50% ÷ 100% I _{max}
Ramp time adjustment	0 ÷ 20 sec
Ambient operating temperature	-20 ÷ +70°C
Current test point	1 Volt = 1 Ampere
Weight	0.120 Kg

(*) For the current signal (mA) the regulator has to be pre-setted in the factory.

REMDRA... INSTRUCTIONS FOR USE

CALIBRATION PROCEDURE

Connect the card in the proper way following the next page "Typical connections" but without powering it. Turn completely anticlockwise (20 turns about) the trimming potentiometers of Minimum Current (I_{min}) and Ramp Time (Ramp-up and Ramp-down), and position the reference potentiometer on zero. Before powering the card, ensure that any unforeseen hydraulic system movement cannot cause material damage or injury to people. Power now the card; the green LED should light up

TWO CHANNEL MINIMUM CURRENT (I_{min}) ADJUSTMENT (DEAD BAND)

Set the reference signal of approx. V_{ref} +150mV. Then turn clockwise the trimmer until an actuator movement can be visually detected (A channel Output LED lights up). Then turn the same trimmer anticlockwise until the movement stops. Repeat the I_{min} calibration for the other channel B. Set the reference signal of approx. V_{ref} -150mV (B channel Output LED lights up).

GAIN ADJUSTMENT

Turn first the ramp time trimming potentiometers (RAMP UP) clockwise by at least 10 turns, if the system could be damaged by a too fast solenoid operation (evaluate the application carefully). The maximum actuator speed can now be adjusted. Turn the reference signal to the maximum positive setting value and rotate slowly the gain trimming potentiometer (GAIN) until the maximum required speed is obtained. The speed can now be varied by moving the potentiometer lever. Repeat the above operations for the other channel after turning the reference signal to the maximum negative value.

RAMP TIME ADJUSTMENT

The ramp time is the time taken to pass from the minimum to the maximum current value, and vice versa. It's adjustable from a minimum of 0s up to a maximum of 20s (to reach the maximum current value setted) separately for channel A and B. Turning clockwise the trimming potentiometer, the ramp time increases.

NOTES

- 1) The ramp fall time affects the actuator stop position. Moving the reference potentiometer to zero Volt, the actuator goes on moving till the setted ramp time is elapsed. Therefore it's necessary to adjust it properly.
- 2) When the overload red LED lights up, it will be necessary to switch off the power to the card, switching it on again after having eliminated the cause of overload.

SIGNALS INPUT REFERENCE

The REMD can receive two kinds of command signal inputs, differential input (non inverting, inverting voltage -5V ÷ +5V), or positive voltage (0V ÷ +5V).

DIFFERENTIAL INPUT REFERENCE

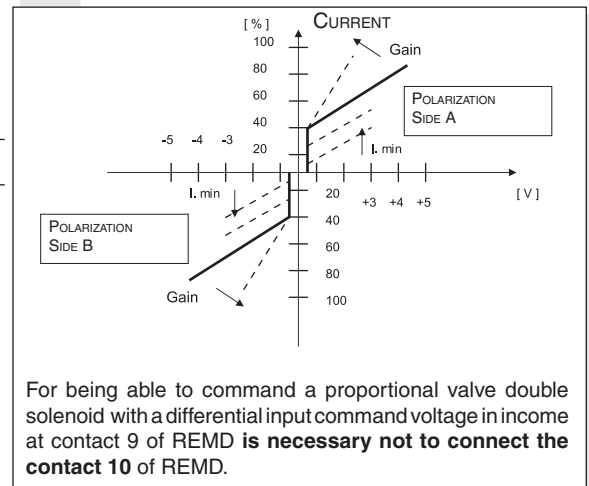

POSITIVE INPUT REFERENCE

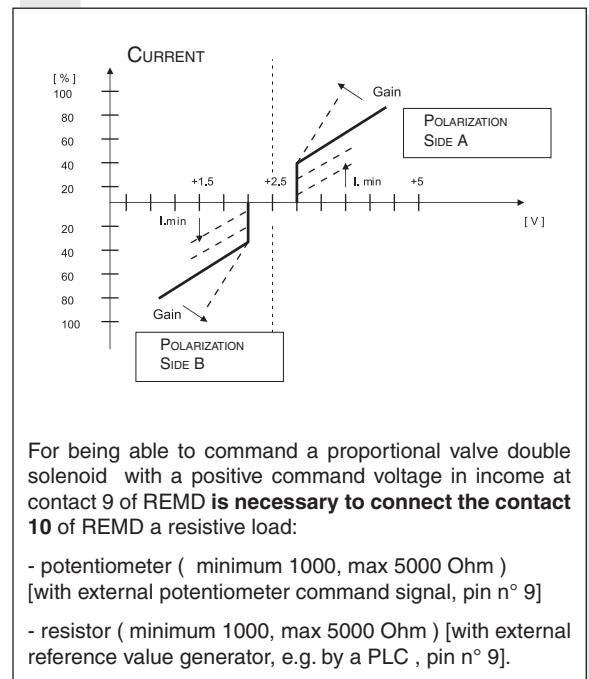

ELECTRONIC REGULATORS DOUBLE SOLENOID PROPORTIONAL CONTROL VALVES

REMDRA... DIP SWITCHE TABLE

Six miniature switches are mounted internally on one of the REM sides. The REM configuration to suit any particular application can be implemented by setting these switches. PWM frequency (100 to 330 Hz), reference voltage range and maximum current (I_{max}) can thus be adjusted.

For our proportional valves are recommended the following settings:

G	XD3C	DITHER =100Hz	I_{max} = 2.35A with 9V coils
G	XDP3C	DITHER =100Hz	I_{max} = 2.35A with 9V coils
G	XD2C	DITHER =100Hz	I_{max} = 1.4A with 12V coils
G	XD3C	DITHER =100Hz	I_{max} = 1.76A with 12V coils
G	XDP5C	DITHER =100Hz	I_{max} = 2.5A with 12V coils
G	XDP3C	DITHER =100Hz	I_{max} = 1.76A with 12V coils
G	XD2C	DITHER =100Hz	I_{max} = 0.7A with 24V coils
G	XD3C	DITHER =100Hz	I_{max} = 0.88A with 24V coils
G	XDP5C	DITHER =100Hz	I_{max} = 1.25A with 24V coils
G	XDP3C	DITHER =100Hz	I_{max} = 0.88A with 24V coils

For the version with reference signal in current it needs to be preset in-factory.

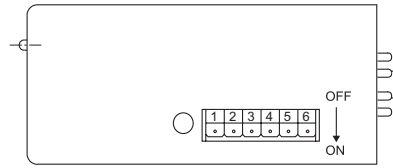

Function	DITHER		I min	Input ref.				I.max.					
	100 Hz	330 Hz		G	-10±10 V	-5±5 V	-2±2 V	-20mA ±20mA	0±5 V	0 ±20mA	2.8 A	1.76 A	0.88 A
1	OFF	ON											
2			ON										
3				OFF	ON	OFF	ON	ON	ON				
4				OFF	OFF	ON	OFF	OFF	OFF				
5										OFF	ON	OFF	
6										OFF	OFF	ON	

TYPICAL CONNECTIONS

command signal from potentiometer supplied by REMD card
- 0 ÷ 2.5V ÷ 5V

signal command from PLC,
0 ÷ 5V, 0 ÷ 20mA

command signal from potentiometer supplied by external power source, ±2V, ±5V, ±10V

signal command from PLC,
±2V, ±5V, ±10V, ±20mA

- The connection between REM and the solenoid must be direct
- The common one of return to proportional solenoid must not be shared between other valve connections or electrical equipment worker.

R = 1000 ÷ 5000 Ω
POT = 1000 ÷ 5000 Ω